



Innovative Energy Systems for a cleaner world

# TransPacific Energy

TransPacific Energy (TPE) is a high-tech corporation that designs, builds, owns, operates, sells, and installs proprietary, modular Organic Rankine Cycle ("ORC") utilizing a multiple refrigerant mixture to recover and convert waste heat (80f to 900f) from industrial processes, solar and geothermal converting it into electrical energy.

TPE uses multi component fluid in contrast to the typical organic Rankine Cycle that uses organic fluid such as pentane, isobutene, butane, propane, and ammonia instead of water. However, these gases are extremely volatile and explosive making them unsatisfactory for most practical applications. Newer pure safer refrigerants have come into wide use but they are very limited in their applications.

The Rankine cycle is a term to describe a thermodynamic model of the operation of steam heat engines (turbines) most commonly found in power generation plants. Current ORC's using pure refrigerants are limited in a very narrow temperature range, usually 200°f-300°f.

This limits their useful application to liquid heat recovery due to concerns over condensation in the stack. Condensation creates numerous problems in combustion exhaust streams, such as sulfuric acids and other caustic chemicals to eat away at the stack and other components making it an undesirable application.

TransPacific Energy has solved that problem by being able to design a system that operates above the dew point.

Our proprietary multiple refrigerant blend enables us to design custom made ORC systems for specific temperatures and applications from 80 °F to 900 °F allowing us to achieve the highest efficiency possible from the designated heat source. This results in the greatest amount of power produced for the heat input, energy savings and creates the optimum return on investment.

## Modularity

Systems are sized from 20 kW up to 20 MW+ modules, containing all the equipment required for the units to be operated (i.e. heat exchangers, piping, working fluid feed pump, turbine, electric generator, controls and switch-gear). Larger units are composed of multiple modules, pre-assembled at the factory. Hence the units are easy to transport and to install, and they are easy to interface with the host facility on site.

## Efficiency

Our efficiency varies between 6% and 25% at temperature from 80 F-900 F respectively. Depending on condensing temperature. Under these conditions we achieve the maximum efficiency allowable compared to that of the theoretical Carnot Cycle.

These are projected and are subject to change and will vary depending on site conditions, flow and temperature input. Please consult us for your specific conditions and application.

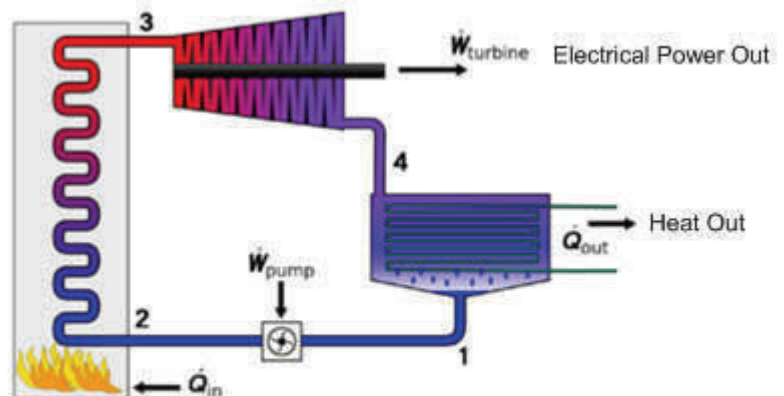

1. Low Pressure Cool Liquid
2. High Pressure Liquid/Vapor
3. High Pressure Hot Gas
4. Low Pressure Hot Gas

- Typical parameters for project assessment are:
- Heat source flow
- Temperature
- Transport Properties & Type of fluid

## Typical Organic Rankine Cycle Systems Comparison\*

	TransPac	Water	134a	245fa	404a	CO <sub>2</sub>	Ammonia	Isobutane
Evaporator Temperature Range (f) <sup>1</sup>	80-900	212+	200-210	200-300	100-150	200-250	210	200-250
Conversion Efficiency (%) <sup>2</sup>	14.0%	11.0%	9.3%	10.9%	6.7%	8.0%	12.6%	14.0%
Typical Recovery Temperature Range (f)	80-900	212+	200-210	200-300	100-150	200-250	200-210	200-250
<b>Applications</b>								
Gas Recovery	Yes <sup>3</sup>	Yes	No	No	No	No	No	No
Liquid Recovery	Yes	Yes	Yes	Yes	Yes	Yes	Yes	Yes
Flammability	No	No	No	No	No	No	Yes <sup>4</sup>	Explosive
Variable Boiling Points <sup>5</sup>	Yes	No	No	No	No	No	No	No

1. Based on typical and recommend operating points

2. Condensing 100F

3. Composition can be changed to recover higher waste temperatures

4. Toxic

5. To recover heat at temperatures >250 F

\* Typical (conditions may vary depending on manufacturer and application)

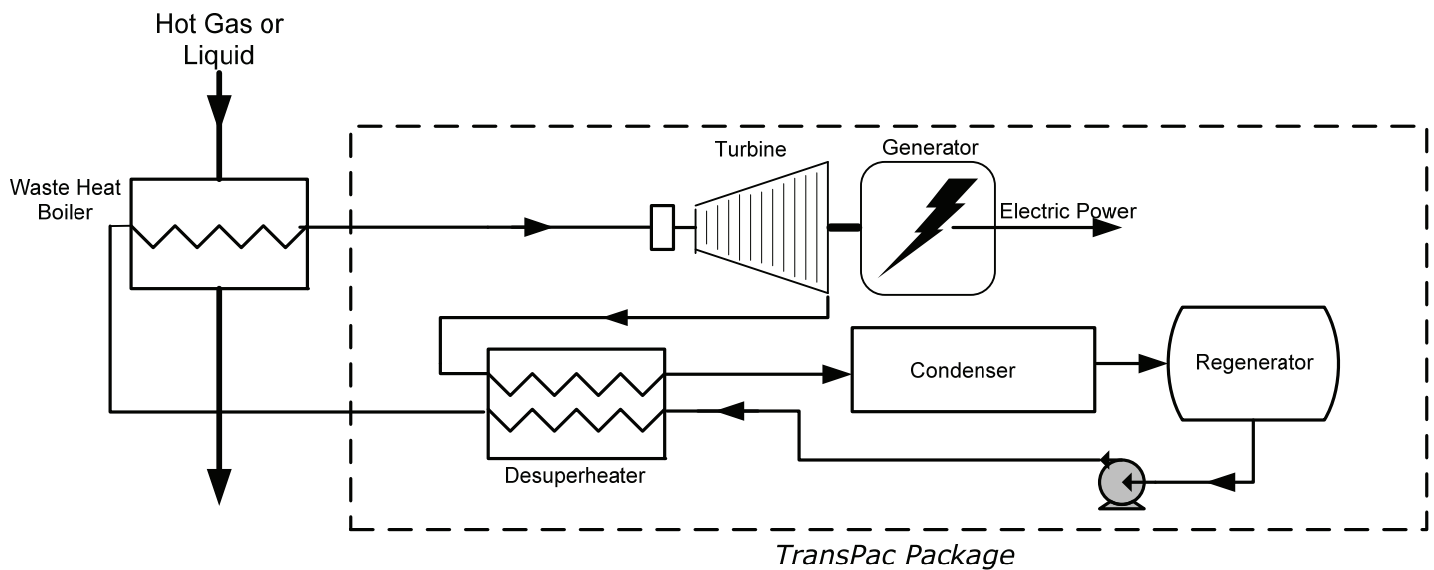

- Complete turnkey package direct drive 3,600 rpm
  - Weather tight enclosure
  - Paralleling switchgear
  - Full DDC controls and remote start and monitoring
  - Factory tested and certified before shipment
  - Single point of connection for power and controls
- Variable speed applications to meet varying load profiles
- Magnetic bearings on the turbine
- Oil Free system
- Engineering boiling points for specific applications and highest efficiency